

CURRENT 3.0 Ampere
 VOLTAGE RANG 20 to 200 Volts

K32 THRU K320

Features:

- Metal silicon junction, majority carrier conduction
- For surface mounted applications
- Low power loss, high efficiency
- Fast switching for high efficiency
- High forward surge current capability
- For use in low voltage, high frequency inverters

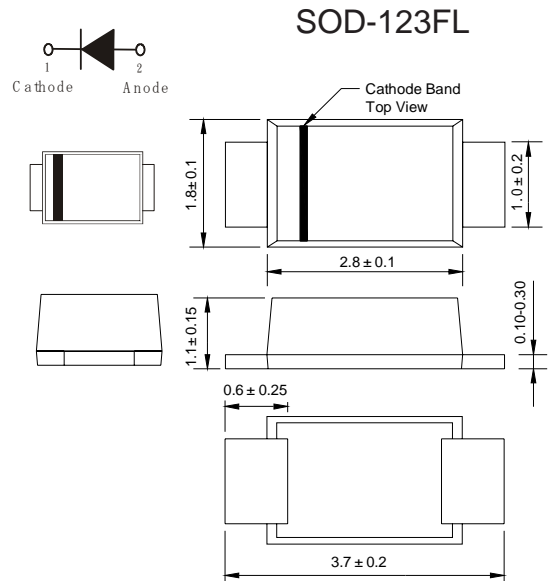

Dimensions in millimeters

Absolute Maximum Ratings* (TA=25°C Unless otherwise noted)

Ratings at 25 °C ambient temperature unless otherwise specified. Single phase, half wave, 60Hz resistive or inductive load, for capacitive load, derate by 20 %

Parameter	Symbols	K32	K34	K36	K38	K310	K312	K315	K320	Units
Maximum Repetitive Peak Reverse Voltage	V_{RRM}	20	40	60	80	100	120	150	200	V
Maximum RMS voltage	V_{RMS}	14	28	42	56	70	84	105	140	V
Maximum DC Blocking Voltage	V_{DC}	20	40	60	80	100	120	150	200	V
Maximum Average Forward Rectified Current	I_{FAV}	3.0								A
Peak Forward Surge Current, 8.3ms Single Half Sine-wave Superimposed on Rated Load (JEDEC method)	I_{FSM}	80								A
Max Instantaneous Forward Voltage at 2A	V_F	0.55	0.70	0.85				0.95		V
Maximum DC Reverse Current I_{R} at $T_a=25^{\circ}C$ at Rated DC Reverse Voltage $T_a=100^{\circ}C$	I_R	0.3			0.2			0.1		mA
		10			5			2		
Typical Junction Capacitance (1)	C_j	220			80					pF
Typical Thermal Resistance (2)	$R_{\theta JA}$	85								°C/W
Operating Junction Temperature Range	T_j	-55 ~ +125				-55 ~ +150				°C
Storage Temperature Range	T_{stg}	-55 ~ +150								°C

(1) Measured at 1 MHz and applied reverse voltage of 4 V.D.C

(2) P.C.B. mounted with 2.0" X 2.0" (5 X 5 cm) copper pad areas.

CURRENT 3.0 Ampere
 VOLTAGE RANG 20 to 200 Volts

K32 THRU K320

Typical Characteristics

FIG.1-TYPICAL FORWARD CURRENT DERATING CURVE

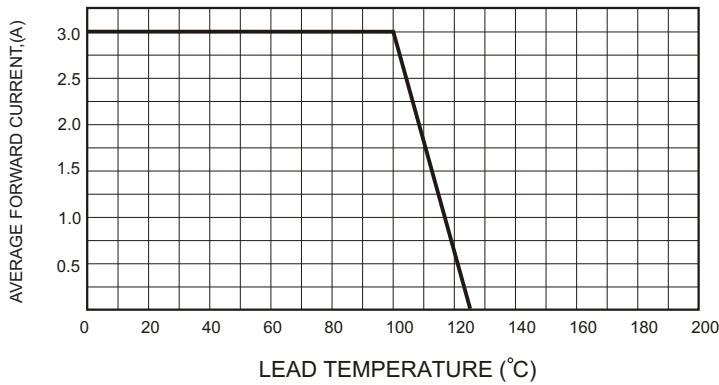

FIG.2-TYPICAL FORWARD CHARACTERISTICS

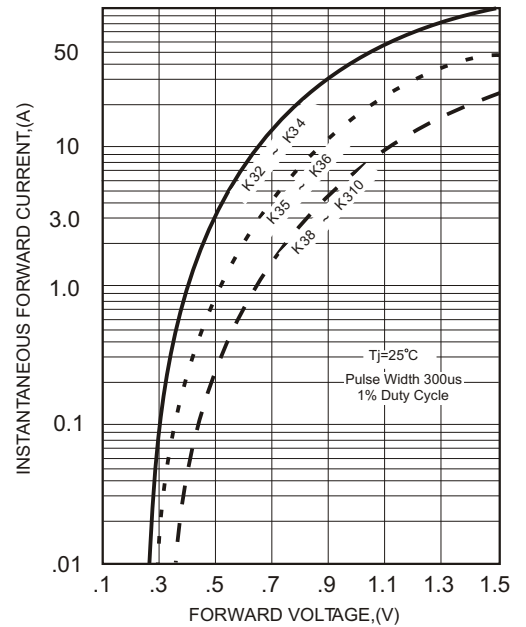

FIG.3-MAXIMUM NON-REPETITIVE FORWARD SURGE CURRENT

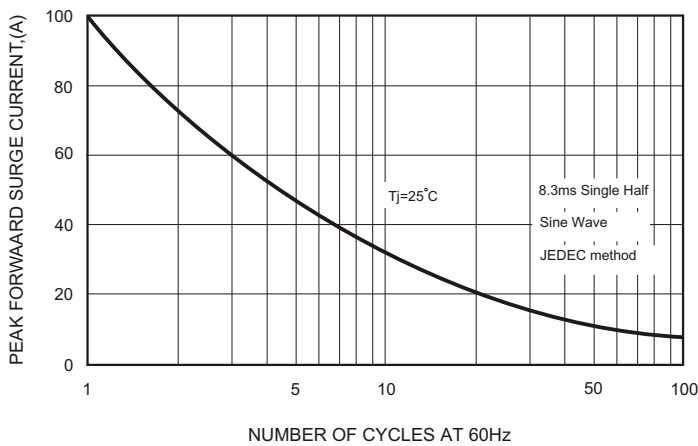

FIG.5 - TYPICAL REVERSE CHARACTERISTICS

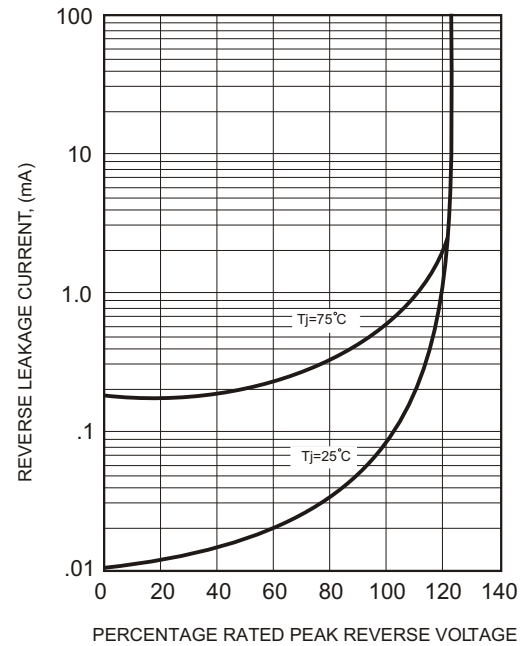
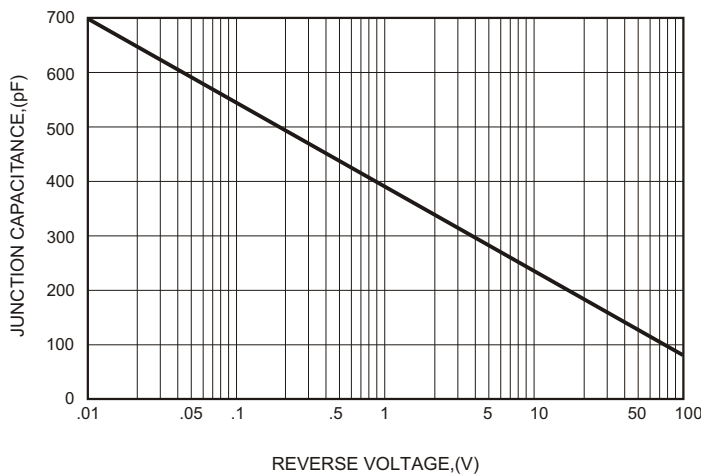

FIG.4-TYPICAL JUNCTION CAPACITANCE



CURRENT 3.0 Ampere
 VOLTAGE RANG 20 to 200 Volts

K32 THRU K320

Package Dimension

SOD-123FL

Unit: mm

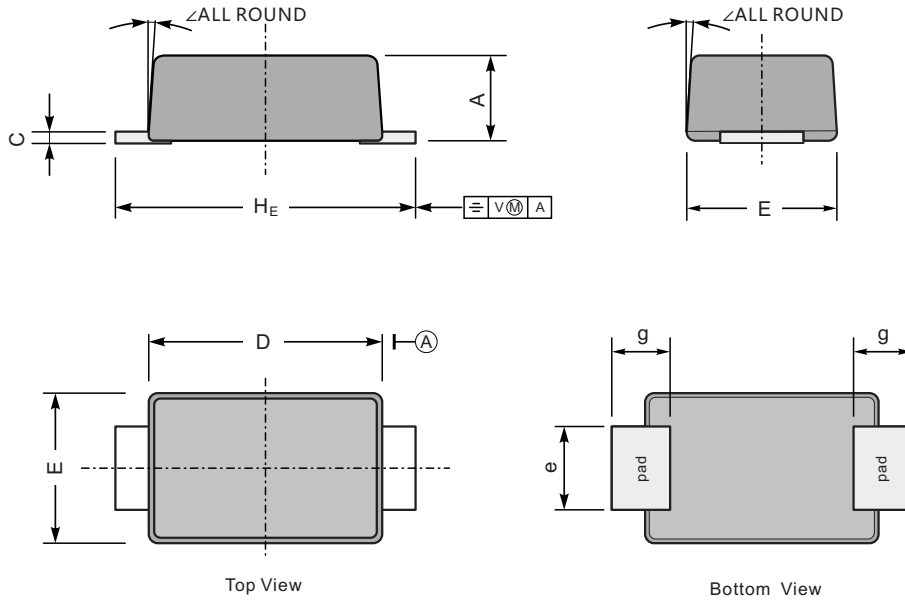

UNIT		A	C	D	E	e	g	H_E	\angle
mm	max	1.1	0.20	2.9	1.9	1.1	0.9	3.8	7°
	min	0.9	0.12	2.6	1.7	0.8	0.7	3.5	
mil	max	43	7.9	114	75	43	35	150	
	min	35	4.7	102	67	31	28	138	

The recommended mounting pad size

